

# Small Parts Planing & Edge Jointing Jig



**[Youtube.com/ericmeyermaker](https://www.youtube.com/ericmeyermaker)**



**[@eric.meyer.maker](https://www.instagram.com/eric.meyer.maker)**

*Eric Meyer*  
05/2021

Not to scale

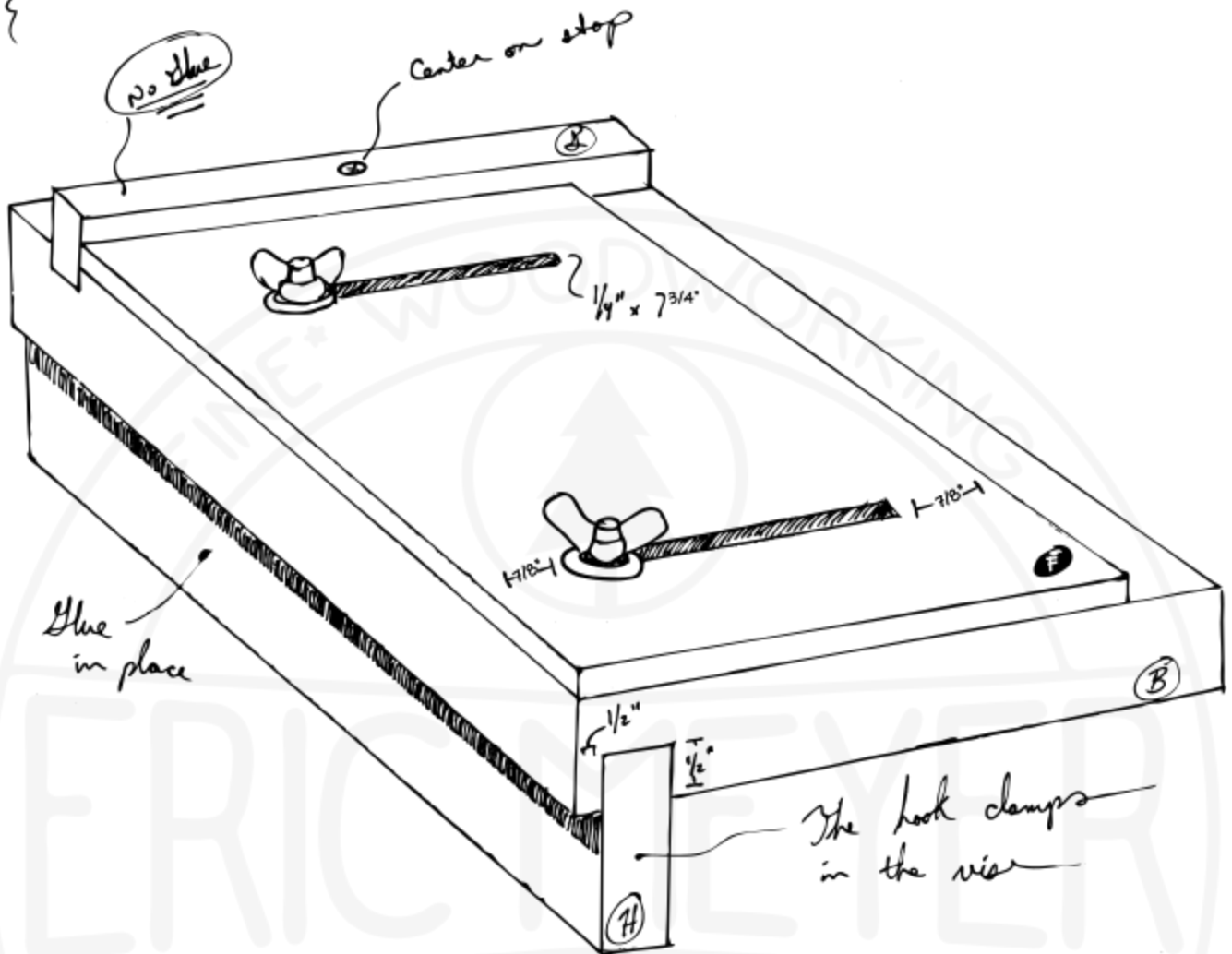

Project: Small Parts Dimensioning Jig

Part (code)	Quantity	T	W	L	Material	Rough	Finished	Notes
Base (B)	1	1"	5-1/2"	11-3/4"				
Fence (F)	1	1/4"	4-1/2"	9-1/2"				
Stop (S)	1	1/2"	1-1/4"	5-1/2"				
Hook (H)	1	3/4"	3-1/4"	11-3/4"				
Dowel (D)	2		5/16"	2"				
Screw	1			1"				
Wing Nut (N)	2		1/4"-20					
Washer (W)	2		1/4" ID					
Threaded Inserts (I)	2		1/4"-20	1"				
Threaded Rod (R)	2		1/4"-20	1-1/2"				I made these from an extra-long bolt that I cut the head off of and then cut in half.

Build notes - Do not over think this. These dimensions are more or less arbitrary. The size of my parts was determined by the piece of scrap lumber I happened to grab. The only "critical" dimension, for me, was the thickness of the base. Keeping the base at 1" thick meant that I could use 1-2-3 blocks to prop up any lumber that needed additional support due to its length or width. You do not need to build this jig to accommodate a 1-2-3 block. Grabbing some scrap wood to support long pieces works just as well. I decided to use 1-2-3 blocks because there is always a couple sitting on my bench.

Not to scale

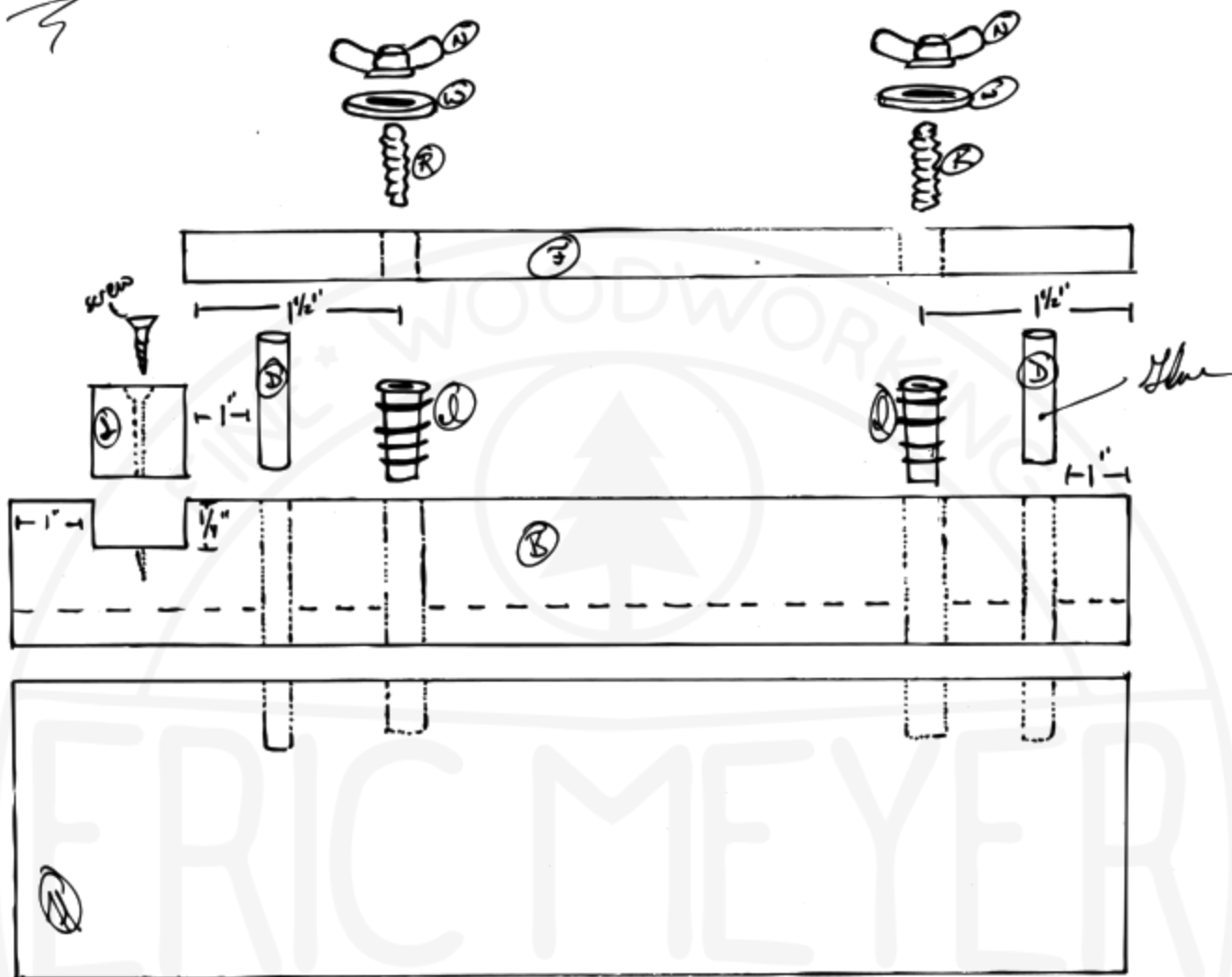

Note - You can watch me make one by visting [youtube.com/ericmeyermaker](https://youtube.com/ericmeyermaker)  
The video is titled "Making a Small Parts Planing and Edge Jointing Jig"

### Instructions

1. Dimension parts B, F, S, H, and D. Tip: You can sand or smooth plane the faces and edges that will be inserted into the dados at this stage. Doing it after the joint is cut could result in gaps.

2. Cut a 1/4" deep dado on the top of B. This dado is inset in from the end of B by 1". Use part S to determine the width and shape of the dado. If the sides of S are not perfectly parallel it is fine. The dado will match either way as it was marked directly from the part.

3. Flip over part B and cut a 1/2" deep groove on the bottom of B. Inset this in from the edge 1/2". Again, use part H to determine the width and shape of the groove to ensure a perfect fit.

4. Return to the top of part B. Mark a line, on the top of B, that would fall approximately in the middle of the groove that was cut for part H. This is where the holes for the dowels and threaded inserts will go.

5. Clamp part H into its groove.
6. Drill two holes that match the diameter of parts D. One is drilled approximately 1" from the dado for part S. One is drilled approximately 1" from the end of B. Drill through B into H.
7. Drill two holes that match the threaded inserts. One is drilled approximately 1-1/2" from the dado for part S. One is drilled approximately 1-1/2" from the end of B. Drill through B into H.
8. Remove H and set it aside.
9. Drill and counter sink a hole in the middle of S for a small screw.
10. Cut two mortises in part F 1/4" x 2-3/4". The placement of these should match the location of the threaded inserts.
11. Add glue to the groove for H, install H, and clamp.
12. Add glue to D and install.
13. Once the glue has setup you can remove the clamps.
14. Install the threaded inserts.
15. Insert part S into its dado. Add the screw to hold it securly. DO NOT add glue. Glue will prevent any seasonal movement in part B and may cause the part to split.
16. Install the threaded rods, add the fense, then washers, and finally the wing nuts.
17. Verify that everything is working as it should.
18. Optional step - Disassemble and smooth any rough areas if you have not already done so. Take care not to alter the fitment of your joints. Tip- You can leave the ends of the boards long and trim them flush after assemply to ensure a perfect match.
19. Optional step - add finish. Tip - If you choose to apply a finish avoid film finishes (Polyurethane, Danish Oil, Shellac, etc) as they can make the surface slippery. Stick to an oil finish like BLO, Pure Tung Oil, Mineral Oil, etc.